

# SPECIFICATIONS - CARACTERISTIQUES SPEZIFIKATIONEN - CARATTERISTICHE

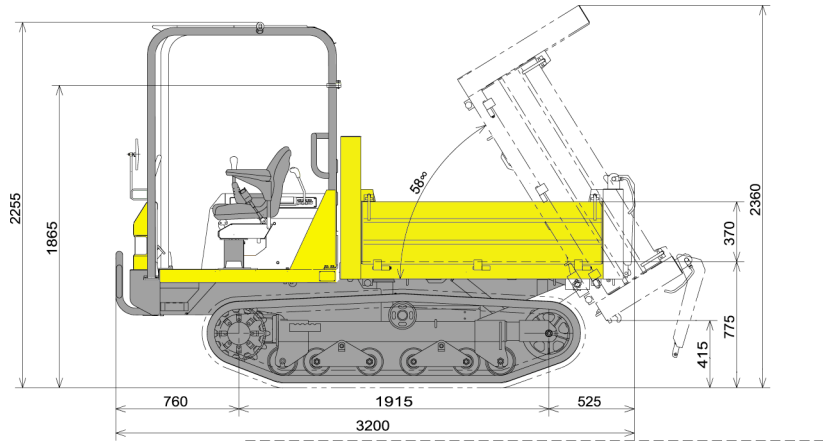

The manufacturer reserves the right to alter vehicle specifications. / Sous réserve de modifications techniques. / Konstruktive Änderungen vorbehalten. / Con riserva di modifiche tecniche.

					<b>C30R2</b>
	<b>Operating weight (rubber crawlers)</b>	<b>Poids de service (chenilles caoutchouc)</b>	<b>Betriebsgewicht (Gummiketten)</b>	<b>Peso operativo (Cingoli in gomma)</b>	<b>2365 kg</b>
<b>ENGINE MOTEUR MOTOR MOTORE (DIN 6270B)</b>	Type	Type	Typ	Tipo	Yanmar 3TNV88-FFW Diesel
	Output HP / kw / rpm	Puissance CV / kw / tr/mn	Leistung PS / kw / U/min	Potenza CV / kw / giri/mn	33,4 / 24,6 / 3000
	Nbr of cylinders - Displacement	Nbre de cylindres - Cylindrée	Anzahl der Zylinder - Hubraum	Qtà dei cilindri - Cilindrata	3 - 1642 cm <sup>3</sup>
	Cooling system	Refroidissement	Kühlung	Raffreddamento	Water / Eau / Wasser / Acqua
	Max torque (N.m. / rpm)	Couple maximum (N.m. / tr/mn)	Max. Drehmoment (N.m. / U/min)	Coppia massima (N.m. / giri/mn)	101 / 1800
	<b>TRANSMISSION</b>	<b>TRANSMISSION</b>	<b>ANTRIEB</b>	<b>TRASMISSIONE</b>	<b>Hydraulic engine with gear</b>
<b>UNDERCARRIAGE CHASSIS INFÉRIEUR FAHRWERK SOTTOCARRO</b>	Track width	Largeur des chenilles	Kettenbreite	Larghezza cingoli	320 mm
	Min. ground clearance	Garde au sol mini	Bodenfreiheit	Luce libera da terra	265 mm
	Ground pressure (unloaded)	Pression au sol (à vide)	Bodendruck (unbeladen)	Pressione al suolo (senza carico)	0,27 kg/cm <sup>2</sup>
	Ground pressure (loaded)	Pression au sol (chargé)	Bodendruck (beladen)	Pressione al suolo (con carico)	0,57 kg/cm <sup>2</sup>
<b>PERFORMANCES PERFORMANCES LEISTUNGEN PRESTAZIONI</b>	Max. payload	Charge utile	Nutzlast	Carico operativo	2500 kg
	Dumping angle	Angle de renversement de la benne	Kippwinkel	Angolo di ribaltamento	58°
	Vessel dimensions (L x W x H)	Dimensions de la benne (L x l x H)	Abmessungen des Kippwagens (L x l x A)	Dimensione (L x l x A)	1685 x 1410 x 370 mm
	Dumping mechanism	Système de basculement	Kippvorrichtung	Tipo di ribaltamento	1 side / 1 côté / 1 seitig / 1 lato
	Dump clearance	Garde au sol benne renversée	Bodenfreiheit Kippwagen in höchster Position	Luce libera da terra sotto il cassone	415 mm
	Dump vessel capacity (struck / heaped)	Capacité de la benne (au niveau des ridelles / avec dôme)	Kippwagenvolumen (randvoll / gehäuft)	Capacità del cassone (al filo sponda / con cumulo)	0,88 / 1,24 m <sup>3</sup>
	Gradeability	Pente maxi	Steigfähigkeit	Pendenza superabile	30°
	Max. travelling speed (forward)km/h	Vitesse de translation (avant) - km/h	Max. Fahrgeschwindigkeit (Vw) - km/st	Velocità di traslazione (av) - km/o	0 - 11
	Max. travelling speed (reverse)km/h	Vitesse de translation (arrière) - km/h	Max. Fahrgeschwindigkeit (Rw) - km/st	Velocità di traslazione (in) - km/o	0 - 11
<b>VARIOUS DATA DIVERS DIVERSE ALTRI DATI</b>	Hydraulic tank	Réservoir hydraulique	Hydrauliktank	Serbatoio idraulico	13 l
	Hydraulic system	Système hydraulique	Hydrauliksystem	Circuito idraulico	18 l
	Fuel tank	Réservoir carburant	Kraftstofftank	Serbatoio combustibile	40 l
	Wet multiple disk brake	Frein à disques multiples immergés dans un bain d'huile	Mehrscheibenbremse in Ölbad	Freno multidischi in bagno d'olio	

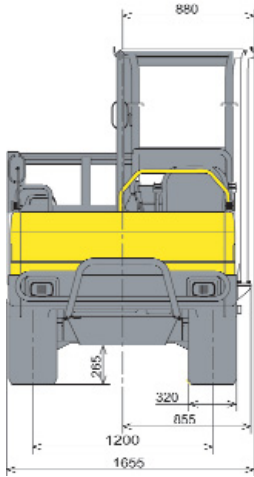
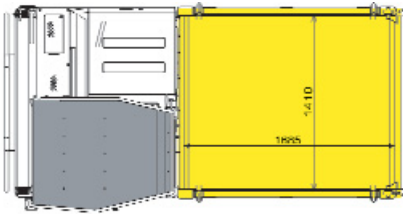

Compact machines

Carriers - Transporter - Trasportatori cingolati

**CBOR2** (Payload : 2500 kg)

The compact equipment expert.